

**Application Guide**  
**for**  
**MasterFlow<sup>®</sup> Epoxy Grouts**  
**MasterFlow<sup>®</sup> 618**  
**MasterFlow<sup>®</sup> 628**  
**MasterFlow<sup>®</sup> 648**  
**MasterFlow<sup>®</sup> 678**

## 1. SURFACE PREPARATION

The foundation surface must be free of all laitance and unsound material and thoroughly cleaned and cured. Keeping the surface covered will make the later job of cleaning the surface prior to grouting much easier and less costly.

The grout foundation should be roughened as specified. As a guide CSP 3 profile 2-5mm (minimum) or CSP 5 profile (3-10mm) (maximum) is recommended. The concrete surface may be uniformly roughened before it has set by the use of a nail rake in one direction only. Use of a bull float, darby, broom, or wood float finish, or scratching at random with a garden rake or trowel is NOT recommended.

After the concrete hardens, hand held, pistol grip pneumatic hammers with chisel point heads are recommended for roughening to remove laitance and loose material to ensure a good bond. The use of large paving breakers equipped with bush hammers, spade or chisel bits, are NOT recommended. Where grout will extend horizontally out beyond the edge of the plate or object grouted, the foundation must also be prepared below these areas to help assure bond.

Before setting structural elements or machinery, all of the areas of the foundation, which will be in contact with the grout, including anchor boltholes, must be thoroughly cleaned. Remove any oil, grease, and curing membrane. Surfaces should be clean and dry before application of the grout.

## 2. FORMING

Forms should be watertight and strong enough to withstand the hydraulic pressure of plastic, flowable or fluid grout, without leaking. When flowing the grout into place, all forms should extend vertically at least 25mm above the underside of the bedplate surface to help ensure complete filling of the space to be grouted and prevent overflowing. The side forms should not be tight against the plate, but should be erected 25 to 50mm horizontally away from the plate so that air being displaced is not trapped below the plate.

If a chamfered edge is required use a fillet edge form work, or diamond cut the grout. A square shoulder is also acceptable for epoxy grouts

The vertical form on the exit side (opposite the placing side) should be extended 50 to 100mm away from the plate so that straps or other placing aids can be inserted to assist movement of the grout should that become necessary.

HEADER BOX - The form on the placing side should be extended 50 to 100mm horizontally from the plate at the foundation and be slanted upward at an approximate 45 degree angle so that grout can be poured on it with a minimum of turbulence (and entrapment of air bubbles) while directing it smoothly on its way under the plate. A backboard (splash board) form should be built on top of the plate and at the plate edge, opposite the slanted headboard, to prevent spillage of grout and provide containment of the "head" of grout as it is being placed.

For many applications, such as turbines and generators, or other base plates of lengthy dimensions, it is not prudent to build high, pouring "head" forms for these base plate lengths. In lieu of this, low forms, sufficiently high to contain the grout and at least 25mm above the bottom elevation of the plate to be grouted may be used. However, as a sloped pouring form is desirable, a portable "head box" which can be moved along the length of the plate as the grouting proceeds may be used. This portable "head box" serves well in helping to place the grout and saves a lot on forming costs.

The box with a sloped pouring surface should rest in part on the form, floor and/or base plate and this method serves just as well, and often better than a long sloped form, as the thrust of the grout flow is better controlled. Another method of pouring large plates is to divide the area to be grouted into sections so that the distance the grout has to flow and the volume to be placed are within the capabilities of the crew. The use of temporary formwork and sectioning the area to be grouted will increase the speed and ease of grouting.

Forms should be caulked to prevent leakage. Forming materials should be coated with a good wax curing compound (such as MasterKure CC 100WB) or plastic coating. These coatings act as bond breakers so that smooth grout surfaces result after form removal and the forms are protected for reuse. The points to caulk are the interfaces between the form and rough foundation surface where grout might leak out during its placement or before setting. Material used for caulking between the form and concrete surface may joint sealants or epoxy mortars. Vertical joints in the forms should be caulked if large cracks are evident. The use of duct tape applied on the inside of the form, at corners, is useful for this.

### **3. STORAGE**

Grout components shall be stored between 10 °C and 30 °C. Note the restrictions on hot and cold weather grouting below.

### **4. MIXING**

#### **MasterFlow 618 and 628**

These products are two parts and should be mixed with a slow speed mixer that minimises air entrainment and operates at speeds less than 300 RPM. The part A should be premixed to ensure that it is homogeneous prior to the addition of the part B and the two should be mixed until they form a homogeneous streak free mixture. The mixer head should remain below the surface of the resin at all times. As a guide mixing should take between 3 and 5 minutes depending on temperature. Longer mixing times may result in shorter pot-life and excess air entrainment. A suitable mixing paddle would be helix type that mixes the product from the bottom up to prevent entrainment of air. A cementitious grout mixer "Bird Cage" is not suitable as it is designed to put energy into the mixing and will entrain air. Apply without delay.

#### **MasterFlow 648 and 678**

These are three part materials.

#### **Small kits:**

When mixing small kits (23.54Kg's) mixing with the same mixer used to mix the resin components may be used although a forced action small pan mixer is preferable. The part B should be mixed into the part A using a low speed (less than 300 RPM less than 100 is ideal) low air-entraining mixer.

If a hand mixer is used then the helical mixing blade should be upward mixing to minimise the entrapment of air (the rotation of the mixer makes the blades move material from the bottom of the bucket to the top of the bucket) and the mixer should be operated at 300 rpm or less. The aggregate should be added slowly and mixed until the product is homogeneous and streak free. The mixer head should remain below the surface of the resin at all times. Do not move mixer up and down during mixing to avoid air entrainment.

**Large kits:**

To mix the large kits a pan mixer (like a Soroto) with a capacity of at least 70 litres. The first bag of aggregate should be added to the pan mixer whilst operating before the resin is added. The part B should be mixed into the part A using a low speed (less than 300 RPM less than 100 is ideal) low air-entraining mixer. The resin should be added slowly to the first bag of aggregate that is mixing in the pan mixer. The additional bags of aggregate are added one at a time slowly mixing until the resin has wetted the whole of the mix. Mix for approximately 2 minutes after the last bag of aggregate is added or until homogeneous. Long mixing times will reduce pot-life and could result in air entrainment. The mixer should be emptied and the grout used without delay. Mixer should be cleaned between mixes to reduce the potential for build-up.

**Trials:**

When conducting trials on epoxy grouts, trials should be carried out using complete kits only and mixed with the equipment that will be used on site. Materials should be as close as possible to the end use products. Trial placement size should be as close as possible to end use.

Small kits: if doing a trial that would involve more than one small kit they should be mixed individually to simulate the placing of multiple kits. The amount of aggregate should be adjusted to ensure that the correct aggregate loading is used (normal or Hi-flow). A small kit (2.56 kg part A, 1 kg or Part B and one 20Kg bag of part C) equates to Hi-Flow loading. If a full mix needs to be achieved with a small kit then an additional 5Kg of the aggregate should be added to the mix.

<b>Normal</b>		
	<b>Single Mix</b>	<b>Normal Large Kit</b>
MasterFlow 648 Part A	2.56	10.16
MasterFlow 648 Part B	1.0	4
MasterFlow 648 Part C	25	100
Total	28.56	114.16
Resin to powder ratio	0.1424	0.1416
<b>Hi Flow</b>		
	<b>Single Mix</b>	<b>Hi Flow Large Kit</b>
MasterFlow 648 Part A	2.56	10.16
MasterFlow 648 Part B	1.0	4
MasterFlow 648 Part C	20	80
Total	23.56	94.16
Resin to powder ratio	0.178	0.177

**5. HOT WEATHER GROUTING**

Avoid high temperatures while grouting. If the packaged grout is above 30°C at time of mixing, chill the sealed pails of grout liquid in a tub of ice, or cover the pails with water-soaked hessian. For large jobs preconditioning of the grout in a temperature controlled environment is recommended. Ensure the mixed grout temperature is less than 30°C. When grouting under hot environmental conditions (ie >30°C), it is necessary to cool the grout and aggregate (if applicable) below 25°C. Provide shade from sunlight for at least 24 hours before and 48 hours after grouting.

## 6. COLD WEATHER GROUTING

Do not use at ambient temperatures of less than 15°C unless artificial means of heating can be used to assist cure. During cold weather, pails of grout liquid should be pre-warmed to between 20°C and 30°C. If heating is required, an enclosure (typical materials are polyethylene or canvas) should be erected around the equipment and foundation and suitable heating used to increase the temperature of the equipment and foundation.

## 7. CRACKING

Cracking may occur on the shoulder near sharp corners of the baseplate and anchor bolts. This is due to lack of restraint at that point and has no impact on long term performance. Horizontal edge cracks may occur just below the grout-concrete plinth interface and do not affect the bearing of the baseplate. The cracking is due to the differences in thermal capacity and most often occurs in external applications. The crack will be limited to the shoulder area and will not affect the ability of the grout to support the equipment. Epoxy injection repair for cracks for cosmetic purposes may be used.

In most cases cracking does not impact the support and alignment performance of the grout. If there is concern regarding the likelihood of cracks allowing oil or chemical contamination of the concrete substrate, the cracks should be filled with a grout binder such as **MasterEmaco 2525**.

## 8. PLATE AND EQUIPMENT PREPARATION

The bonding surfaces of the base or plate to be grouted shall be sandblasted to “white metal” and be free of coatings, wax, grease or scale. Where new plant and equipment have been surface finished with high quality coating systems such as polyurethane coatings these need not be removed. Other mechanical methods such as grinding or sanding are also effective but do not produce as high bond strength as sandblasting. To permit easy clean up, wax or cover all surfaces where the grout may splash.

## 9. DEEP POUR RECOMMENDATIONS

For deep pours up to 150mm, **MasterFlow 648** is recommended. For deep pours greater than 150mm and up to 450mm, **MasterFlow 678** is recommended.

Optional extra reinforcing for high volume (more than half a cubic meter) a deep pour is necessary, 10-12mm steel reinforcement at 300-450mm centres may be used to minimise stress cracking. The top tier should be located about 50mm below the equipment base. A bottom tier should be placed about 50mm above the foundation surface. Additional tiers, if required, should be spaced equal distances in the grout pour with vertical supports as required.

## 10. ANCHOR BOLT GROUTING

Bolts must be free of oil, grease and rust. Solvent wipe before placement with **MasterSeal 955**  
Bolts must be deformed bar, fish tail or threaded rod, with nut or head preferred.  
Grit blasting or abrasive wheel may be required to remove scale or rust.

**Holes drilled dry** must have dust blown out and be free of oil and grease. Wet drilled holes must have free water rinse to remove drilling slurry. Formed holes must be chipped to remove laitance, form oil residue. If polystyrene was used for forms, do not melt with petrol or thinner because a sticky residue will remain. Mechanically remove polystyrene and clean hole with wire brush or scraper on a vibrating hammer.

### **Hole Dimensions**

Hole Depth - 12 times bolt diameter  
Hole Diameter - 1.5 times bolt diameter. Over 600mm deep a minimum of plus 50mm bolt diameter is recommended.

### **Hole spacing at edges**

Edge spacing and space between holes is bolt diameter x 8. Shear loads acting to the edge of concrete will need to be considered separately.

## **11. BULKING WITH AGGREGATES**

Mixing aggregate in:

- **MasterFlow 678** and **MasterFlow 648** have aggregate (supplied by Master Builders Solutions) mixed in as standard – refer to appropriate technical data sheets for more details.
- **MasterFlow 618** has the ability to be bulked out with aggregate/filler supplied by Master Builders Solutions. Use 15kg of Filler F1 per 10kg kit in large void situations with little reinforcement. In applications requiring higher flow, use 10kg of **MasterFlow 618** Filler per 10kg kit.

Another method of bulking out **MasterFlow 618** is the addition of 2 parts by volume of 10mm aggregate to 3 parts **MasterFlow 618**. However, the product is only just pumpable at this ratio.

## **12. PUMPS**

Pumps can be used for **MasterFlow 648** and **MasterFlow 678** for large baseplates or large volumes and the best are diaphragm pumps. They are easily stripped, not affected by solvent, readily available, air powered, cheap and will be abrasion resistant. The use of pump hoses will assist in proper placement and a minimum internal diameter of 50mm is recommended. The hose should be placed at the furthest point to be grouted and slowly withdrawn as the grout is pumped and fills the void.



Figure 1 - Slow speed mixer



Figure 2 - Adding aggregate or Part C to mixer

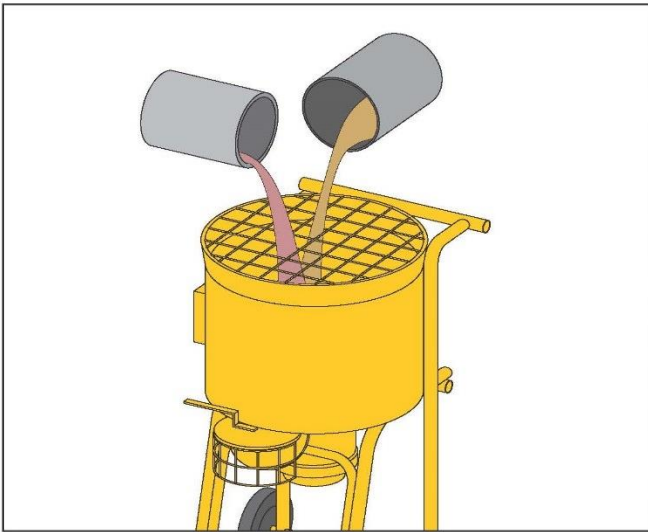

Figure 3 - Adding resin and hardener to mixer (either individually or premixed)

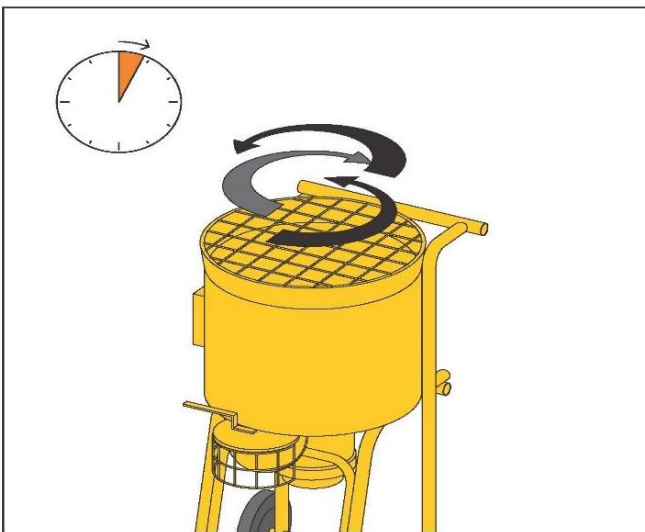

Figure 4 - Mix for 5 minutes at slow speed



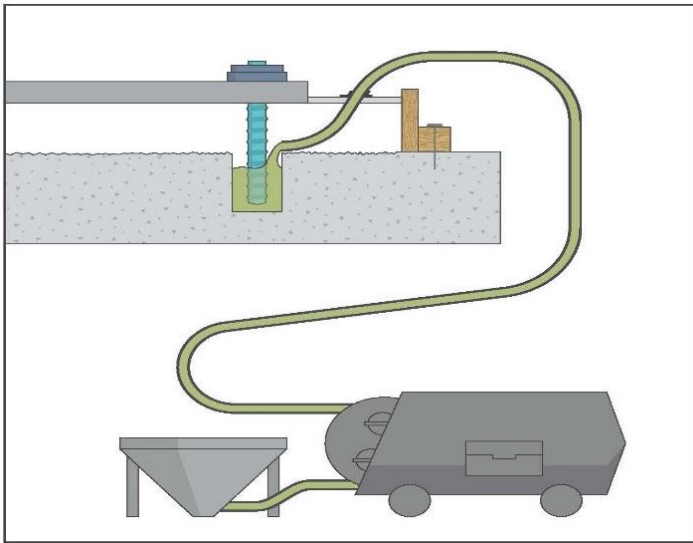

Figure 5 - Filling bolt pockets with a pump

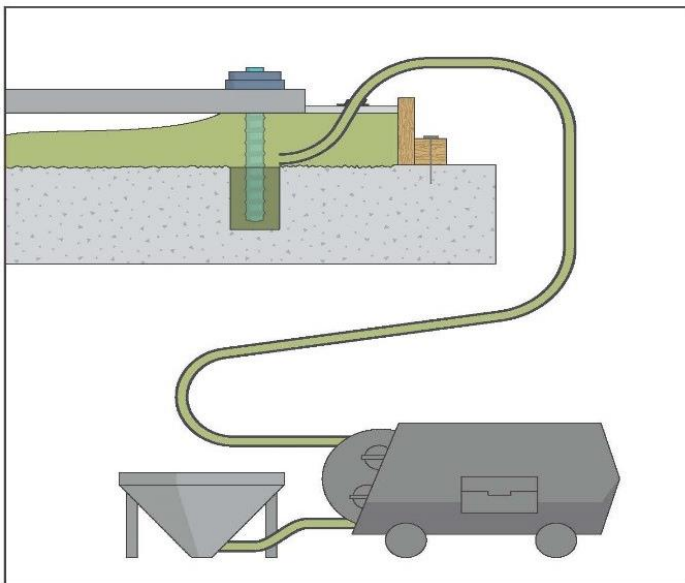

Figure 6 - Grouting under the plate with a pump

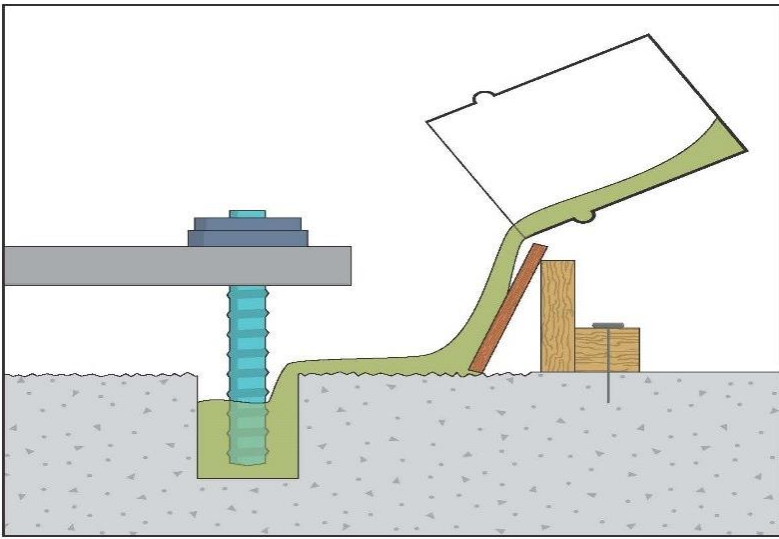

Figure 7 - Filling bolt pockets with grout mixed in buckets showing the sloping board to minimise air entrapment

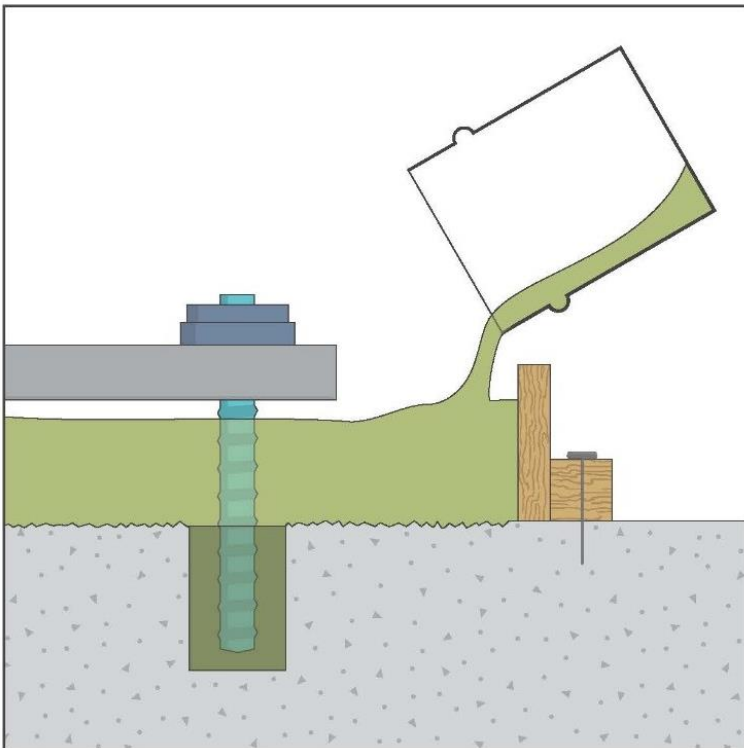

Figure 8 - Grouting under the plate with multiple buckets

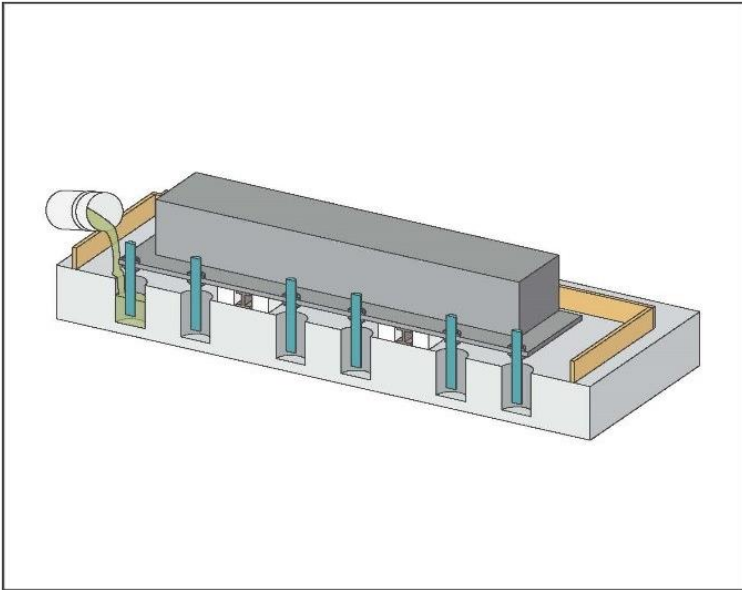

Figure 9 - Grouting bolt holes on a large multi pour job

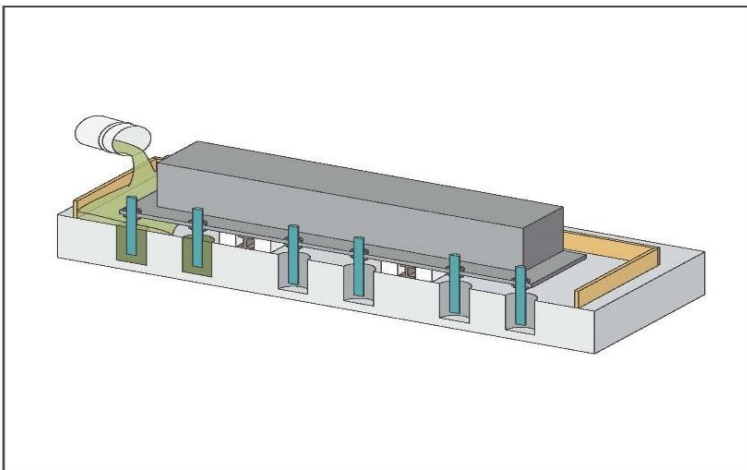

Figure 10 - Grouting the first section of a large multiple pour job

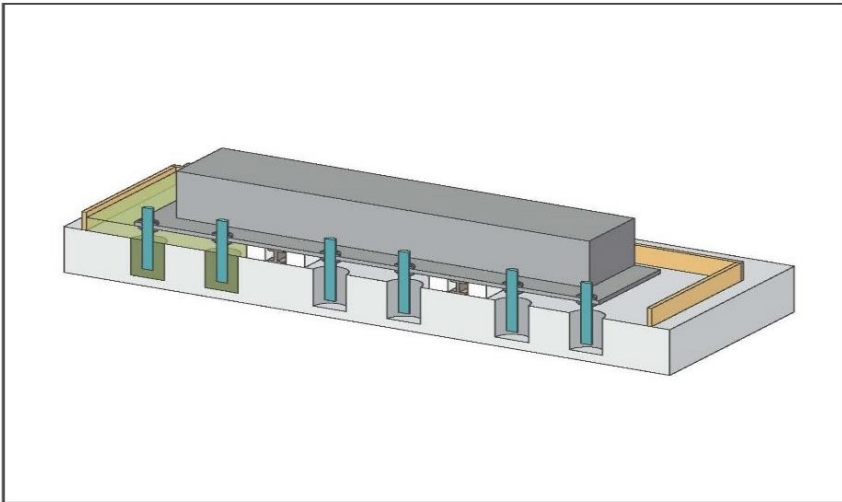

Figure 11 First section grouted

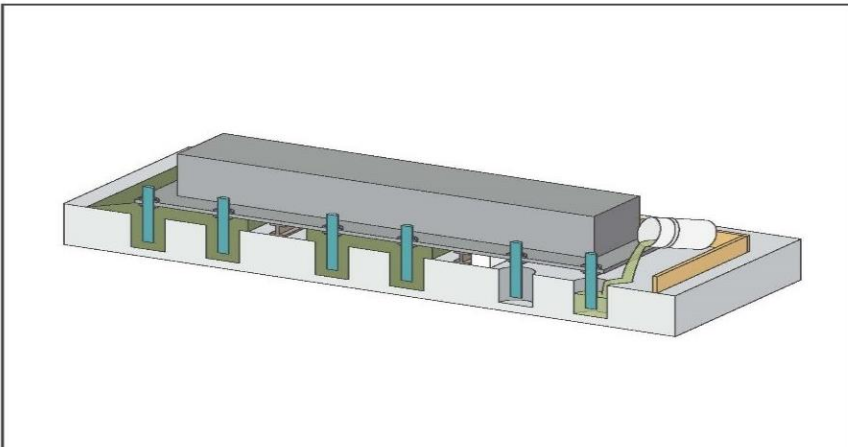

Figure 12 - Continue with each section removing the temporary formwork as you go

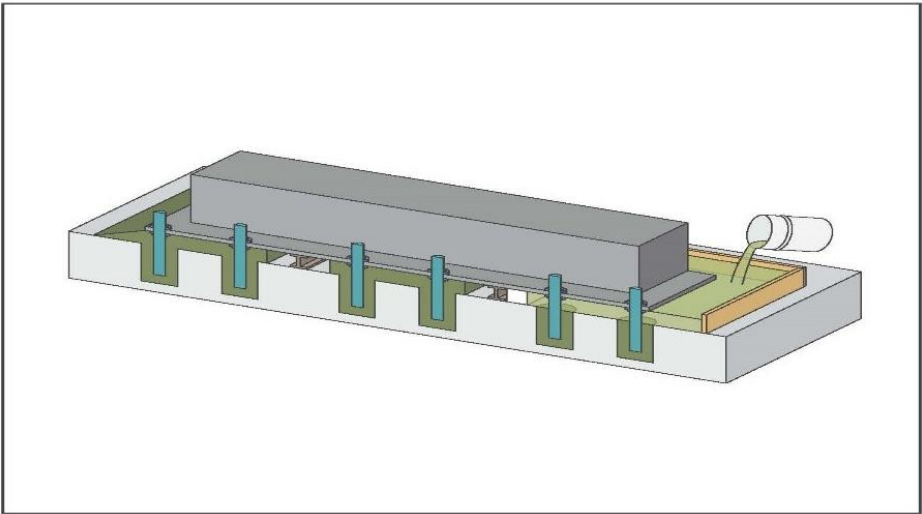

Figure 13 - Continue till all sections are done

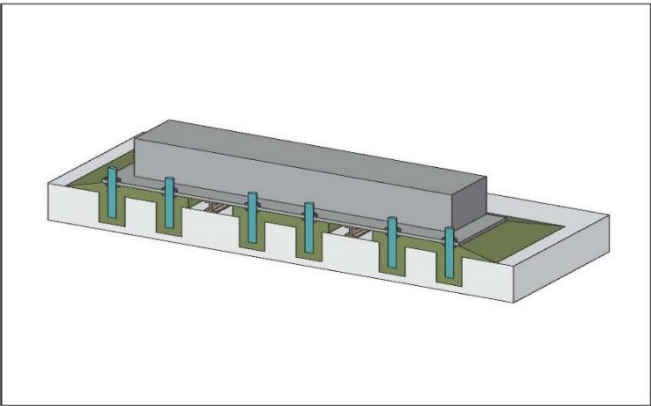

Figure 14 - Finished baseplate

## DISCLAIMER

Application Guide for MasterFlow Epoxy Grouts V11 032021

<b>STATEMENT OF RESPONSIBILITY</b>	The technical information and application advice given in this MB Solutions Australia Pty Ltd publication are based on the present state of our best scientific and practical knowledge. As the information herein is of a general nature, no assumption can be made as to a product's suitability for a particular use or application and no warranty as to its accuracy, reliability or completeness either expressed or implied is given other than those required by law. The user is responsible for checking the suitability of products for their intended use and for ensuring that the application and use of the product is in accordance with the manufacturer's guidelines and recommendations.	
<b>NOTE</b>	Field service where provided does not constitute supervisory responsibility. Suggestions made by MB Solutions Australia Pty Ltd either orally or in writing may be followed, modified or rejected by the owner, engineer or contractor since they, and not MB Solutions Australia Pty Ltd, are responsible for carrying out procedures appropriate to a specific application.	
<b>MB Solutions Australia Pty Ltd</b> ABN 69 634 934 419 11 Stanton Road Seven Hills NSW 2147  <b>Freecall: 1300 227 300</b> <a href="http://www.master-builders-solutions.com/en-au">www.master-builders-solutions.com/en-au</a>	<b>MB Solutions New Zealand Ltd</b> 45C William Pickering Drive Albany, Auckland New Zealand  <b>Freecall: 0800 334 877</b>	<b>Emergency Advice:</b> 1300 954 583 within Australia (24hr) 0800 001 607 within New Zealand